

**Keep This Manual  
With Air Conditioner**



**AIR CONDITIONER  
OPERATOR'S MANUAL**

**CAUTION**

BEFORE INSTALLING AND  
USING THIS AIR CONDITIONER,  
IT IS IMPORTANT THAT THIS  
MANUAL BE READ AND  
UNDERSTOOD THOROUGHLY

**KOOLTRONIC, INC.**  
30 Pennington-Hopewell Road  
Pennington, NJ 08534  
609•466-3400  
FAX: 609•466-1114  
[www.kooltronic.com](http://www.kooltronic.com)

# ***TABLE OF CONTENTS***

		Page
I.	Introduction	2
II.	Incoming Inspection	3
III.	Product Handling	3
IV.	Product Identification Label	4
V.	Principles of Operation	5
VI.	Pre-Installation Testing	6
VII.	Specific Model Data	7 - 10
	Mounting	
	Drawings and Dimensions	
	Technical Data	
	Major Component Replacements	
	Wiring Schematics	
VIII.	Maintenance	11-12
IX.	Trouble Shooting	13
X.	Accessories	14
XI.	Warranty	15

## ***I. Introduction***

Kooltronic Air Conditioners are designed to provide a cool, dehumidified environment for your electronic components. There are models to fit virtually all sizes and shapes of electronics enclosures, in capacities ranging from 1,000 to 60,000 BTU/H. Our "closed-loop" design also ensures that your components will not be exposed to hot, dirty operating conditions.

This Manual provides you with the necessary general information for properly installing and operating standard Kooltronic Air Conditioners. Technical data and mounting instructions are presented on pages 7 through 10.

## ***II. Incoming Inspection***

Kooltronic Air Conditioners are designed, built and packaged to withstand the shock and vibration normally associated with shipment by common carriers. Occasionally improper handling during shipping causes damage. Such handling could include unbanding of palletized shipments, failing to respect "**This Side Up**" arrows, rough handling, falling off conveyors, excessive vibration, crushing, etc. Therefore, a thorough inspection should be done upon receipt of all shipments. Any carton tears, dents, scratches, loose articles or evidence of oil are signs of damage and should be noted on the Freight Bill. Cartons should be opened promptly and the units inspected for CONCEALED DAMAGE. Kooltronic Air Conditioners must be delivered in the proper mounting position to assure that damage to the compressor has not occurred during shipping. Any Kooltronic Air Conditioner that is delivered removed from the banded pallet, lying down or double stacked should be refused.

An immediate claim **MUST** be filed with the freight carrier and an inspection requested. Retain all packing materials. Kooltronic cannot assume responsibility for Consignee's failure to file a timely freight claim.

## ***III. Product Handling:***

- 1) Do not attempt to operate your Kooltronic Air Conditioner until you read and thoroughly understand this Manual. See section **VI PRE-INSTALLATION TESTING**.
- 2) Before operating the Kooltronic Air Conditioner be certain that it is placed in its correct mounting position. **All Air Conditioners containing an M, P, or V as part of the model number are designed to operate in a vertical position only. All Air Conditioners containing an H in the model number are designed to operate in a horizontal position only.** This placement must be done a minimum of 5 minutes prior to operating in order to allow the compressor oil to drain to the compressor sump area.

### ***CAUTION***

**Kooltronic Air Conditioners must be operated in their proper mounting position. If attempts are made to operate a unit that is not in its designed mounting position, permanent compressor damage will occur. This action will void the warranty. To avoid compressor damage do not tip the unit more than 45° from its proper mounting position.**

- 3) Before operating this unit, all electrical wiring must be checked to assure the proper connection to the correct power source. Minimum circuit ampacity should be at least 125% of the amperage found on the air conditioner label for the corresponding voltage. Do not exceed the maximum fuse size found on the label.
- 4) We do not recommend that Air Conditioners be shipped to their final destination attached to an enclosure. In the event that the Air Conditioner needs to be shipped attached to an enclosure it is strongly recommended that proper support be provided for the Air Conditioner. Excessive vibration can occur if Air Conditioners are not properly supported when shipped on enclosures, increasing the potential for internal damage and voiding the warranty.
- 5) **PROCEDURE FOR PROPER PACKING AND SHIPMENT OF KOOLTRONIC AIR CONDITIONERS:**
  - Keep Air Conditioner in proper upright position indicated by arrow markers.
  - Pack Air Conditioner in an appropriate carton (preferably original carton if possible), with adequate internal protective packaging, making sure carton is marked and is kept in correct upright position.
  - For local, controlled transportation, strap carton to a secure part of truck to prevent falling or sliding, minimize vibration, etc.
  - For common carrier shipment, band unit(s) securely to a pallet. Unpalletted shipment risks severe damage which voids the warranty.

## IV. Product Identification and Labels

Each Kooltronic Air Conditioner includes an identification label. This label provides:

- ① Model Number
- ② Serial Number
- ③ Electrical power characteristics
- ④ Maximum and minimum ambient operating temperatures
- ⑤ Cooling capacity
- ⑥ Type and amount of refrigerant required for recharging
- ⑦ Design Pressure

We recommend you copy this information from your unit.

MODEL NO.			SERIAL NO.		
①				②	
VOLTS.	FREQ.	PH.	COOLING F.L.A.	AMBIENT TEMP. MIN. °F	MAX °F
③	③	③	③	④	④
COOLING BTU			REFRIGERANT		
⑤			⑥		
DESIGN PRESSURE P.S.I.G.			MAX. FUSE SIZE		
LOW	HIGH		③		
⑦	⑦				

SERVICE AIR FILTERS REGULARLY  
ALLOW 5 MIN. BEFORE RESTARTING AFTER SHUTDOWN  
UNAUTHORIZED SERVICE OR MODIFICATION VIOLATES WARRANTY  
ALL MOTORS ARE THERMALLY PROTECTED

THIS PRODUCT IS PROTECTED BY ONE OR MORE OF THE FOLLOWING PATENTS: 3,019,965 3,120,166 3,211,360 3,559,728 3,807,493 AND OTHER PATENTS PENDING

MANUFACTURED BY:  
KOOLTRONIC, INC. PENNINGTON, NJ VENTURA, CA

① ② When ordering parts, specify the Model Number and Serial Number.

③ Before operating, be sure that the power source matches these requirements.

④ Make sure that these parameters are met. Failure to do so may result in permanent damage to the unit

⑥ Use of incorrect type or amount of refrigerant will adversely affect performance and may damage the unit.

## V. Principles of Operation

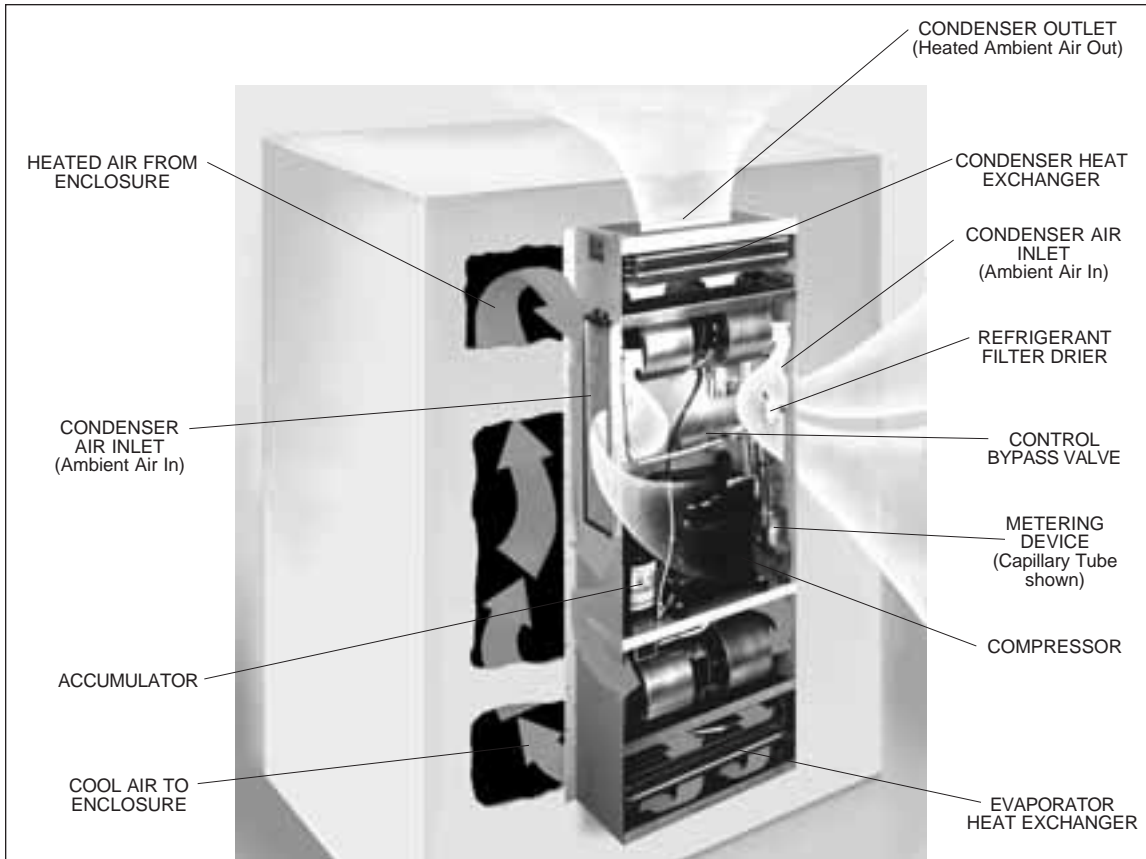

Kooltronic Air Conditioners are required when the equipment operating temperature must be kept near or lower than the ambient room temperature, and/or the cabinet must be sealed from dust, fumes, oil, corrosives and other contaminants. This Air Conditioner utilizes a "Closed-Loop Cooling System" to ensure optimum performance of the installed components.

Closed-Loop cooling seals the electronics enclosure from hostile elements in the environment. Two separate circulation systems are employed. The internal system cools and dehumidifies the air inside the cabinet, totally isolating the sensitive electronics and other components from the environment. The external system uses circulating ambient air or water to discharge the heat removed from the electronics. The heat is dissipated from the enclosure by means of the vapor compression refrigeration cycle. This takes place in a hermetically-sealed refrigeration system, utilizing either an air-cooled or water-cooled condenser heat exchanger. The warm air inside the enclosure is drawn through the evaporator coil where it is cooled, dehumidified and returned.

Any enclosure moisture accumulated on the evaporator coil is collected in the condensate tray and released to the ambient air through the drain tube or the condensate evaporator.

The heat removed through the evaporator coil is transferred by the compressed refrigerant to the condenser coil. Ambient air or water is then passed through the condenser coil, where it absorbs the heat and is then discharged to the environment.

Kooltronic Air Conditioners are designed to operate continuously in order to eliminate compressor cycling, which shortens compressor life and causes line transients. The cool air discharge temperature is regulated by the capacity control (hot gas bypass) valve. The unit is equipped with a Low Temperature Thermostat to prevent over-cooling. In applications having frequent voluntary or involuntary power interruptions, a Short Cycle Protector is recommended to allow adequate time for the internal pressures of the Air Conditioner to equalize before restarting.

Any enclosure moisture accumulated on the evaporator coil is collected in the condensate tray and released to the ambient air through the drain tube or the condensate evaporator.

The heat removed through the evaporator coil is transferred by the compressed refrigerant to the condenser coil. Ambient air or water is then passed through the condenser coil, where it absorbs the heat and is then discharged to the environment.

Kooltronic Air Conditioners are designed to operate continuously in order to eliminate compressor cycling, which shortens compressor life and causes line transients. The cool air discharge temperature is regulated by the capacity control (hot gas bypass) valve. In applications subject to over-cooling, a Low Temperature Control (thermostat) should be considered. In applications having frequent voluntary or involuntary power interruptions, a Short Cycle Protector is recommended to allow adequate time for the internal pressures of the Air Conditioner to equalize before restarting.

## ***VI. Pre-Installation Testing***

The Air Conditioner may be operated during receiving inspection without a heat load. **ON THERMOSTAT-EQUIPPED UNITS, IF THE COMPRESSOR AND CONDENSER BLOWER (AMBIENT SIDE) FAIL TO OPERATE, THE THERMOSTAT MAY NEED ADJUSTMENT.**

- Adjust Thermostat setting downward until compressor and condenser blower start. (Note factory setting first)
- If unit is tested without heat load, be sure to reset Thermostat to factory setting prior to installation and operation.

### ***CAUTION***

**The Air Conditioner must be standing in its proper mounting position for a minimum of five (5) minutes prior to testing. Failure to follow this procedure will cause permanent damage to the compressor.**

Refer to the identification label for proper electrical current requirements. Then connect the power cord to a properly grounded and fused electrical supply.

Operate the Air Conditioner for approximately ten (10) minutes. During this period no unusual noise or vibration should be evident. Both the condenser and evaporator blowers should be delivering air through their respective discharge ports. The cool air discharged should be less than 70° Fahrenheit when the room temperature is between 70° and 80° Fahrenheit. If the compressor and condenser blower (ambient side) fail to operate on thermostat-equipped units, the thermostat may need adjustment. If any cover plug is removed to adjust the unit, make certain to put the cover plug back in place to maintain the integrity of the closed-loop airflow system.

**NOTE:** Before shipment all Kooltronic Air Conditioners are subjected to a cooling performance test at the rated capacity.

## VII. Specific Model Data

### Mounting

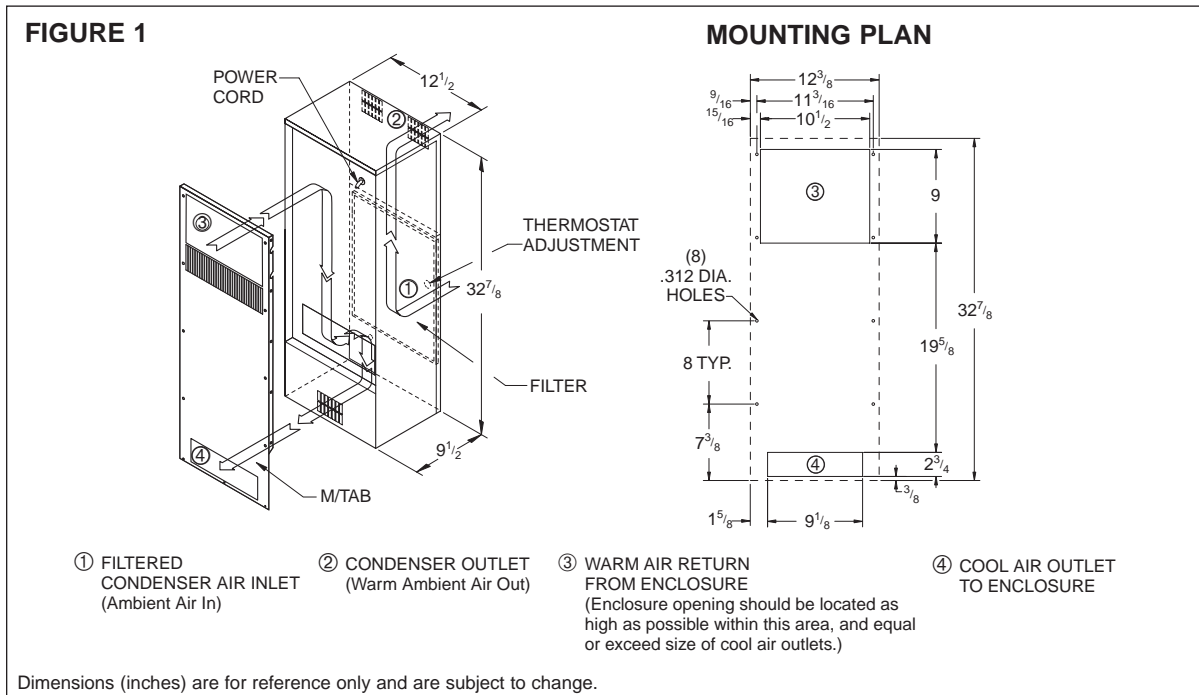

Kooltronic Air Conditioners have been engineered to be installed easily. To avoid damaging your Air Conditioner, please read the following information before installation:

1. Remove and save the four screws holding the Mounting Template and Assembly Bracket (M/TAB) to the unit. Remove the M/TAB.
2. See Figure 1 for proper M/TAB orientation. Place the M/TAB flush against the outside of the cabinet to locate cutouts and mounting holes.
3. NOTE: The top cutout for the warm air return does not have to match the full 9" opening on the M/TAB. You can locate your cutout anywhere within this opening. Locate your cutout close to the top and not less than 3" high. Make sure the cutouts don't interfere with components inside your cabinet.
4. Mount the M/TAB to the outside of the cabinet using all the mounting hardware supplied by Kooltronic ( $\frac{1}{4}$ "-20 screws/nuts/washers). NOTE: Make sure the screws are inserted with heads on M/TAB side. Tighten nuts securely.
5. Route the power cord through the top cut out in your cabinet. Mount the unit to the M/TAB by sliding the studs located on each side panel into the slots on the M/TAB.
6. Insert the remaining 10-32 screws and seal washers supplied by Kooltronic through the Air Conditioner side panel and into the M/TAB. To avoid misalignment of parts do not tighten any of the screws until they are all installed. Be careful not to overtighten the screws.
7. Attach overflow drain hose supplied to the drain exit in the side or bottom of the unit. This hose must not be elevated above the exit port. Improper mounting will impede the flow of condensate and may cause internal malfunctions.

### CAUTION

**If the Air Conditioner is mounted to the cabinet door you must be sure that the door hinges will support the additional weight of the Air Conditioner. Also be certain that when the door is opened fully, the cabinet does not become unbalanced. The actual weight of the unit can be found in the performance specifications.**

# Drawings and Dimensions

## NP33 SERIES

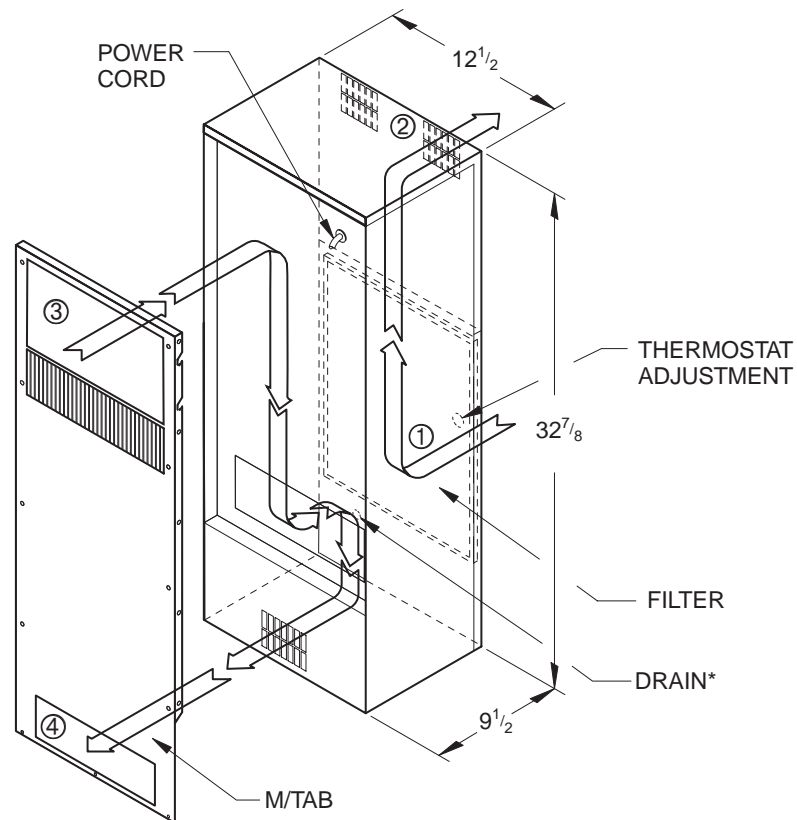

① FILTERED  
CONDENSER AIR INLET  
(Ambient Air In)

② CONDENSER OUTLET  
(Warm Ambient Air Out)

③ WARM AIR RETURN  
FROM ENCLOSURE  
(Enclosure opening should be located as  
high as possible within this area, and equal  
or exceed size of cool air outlets.)

④ COOL AIR OUTLET  
TO ENCLOSURE

\* Other drain outlets are available - contact KOOLTRONIC

Dimensions (inches) are for reference only and are subject to change.

## Technical Data

Model	** BTU/H Rating	Ambient Temp. °F Max./Min.	◇ Volts	◇ Hz	** Running Amps	Approximate Weight (lbs.)
KA4C2NP33L	2000	125/50	115/100	60/50	12.8	90
KA4C2NP33L56	2000	125/50	115	50/60*	12.8	90
K2A4C2NP33L	2000	120/50	230/200	60/50	5.5	90
K2A4C2NP33L5	2000	120/50	230	50	5.8	90
KA4C3NP33L	3000	125/50	115/100	60/50	12.8	90
KA4C3NP33L56	3000	125/50	115	50/60*	12.8	90
K2A4C3NP33L	3000	120/50	230/200	60/50	5.5	90
K2A4C3NP33L5	3000	120/50	230	50	5.8	90
<b>KA4C4NP33L</b>	<b>4000</b>	<b>125/50</b>	<b>115/100</b>	<b>60/50</b>	<b>12.8</b>	<b>90</b>
<b>KA4C4NP33L56</b>	<b>4000</b>	<b>125/50</b>	<b>115</b>	<b>50/60*</b>	<b>12.8</b>	<b>90</b>
<b>K2A4C4NP33L</b>	<b>4000</b>	<b>120/50</b>	<b>230/200</b>	<b>60/50</b>	<b>5.5</b>	<b>90</b>
<b>K2A4C4NP33L5</b>	<b>4000</b>	<b>120/50</b>	<b>230</b>	<b>50</b>	<b>5.8</b>	<b>90</b>
KA4C5NP33L	5000	125/50	115/100	60/50	12.8	90
KA4C5NP33L56	5000	125/50	115	50/60*	12.8	90
K2A3C5NP33L	5000	125/50	230/200	60/50	7.0	90
K2A3C5NP33L5	5000	125/50	230	50	6.5	90

Units in **BOLD** are current standard products. Other units are prior product offerings and shown for reference only.

\* Switchable. Switch is internally-mounted for security.

\*\* Rating shown is for operation at maximum ambient temperature.

◇ 115V, 60 Hz and 230V, 60 Hz models also perform at full capacity when operated at 100V, 50 Hz or 200V, 50 Hz respectively. No transformer is required.

## Major Component Replacements

Part	KA4C_NP33	K2A4C_NP33	K2A3C_NP33
	2,000-5,000 BTU	2,000-4,000 BTU	5,000 BTU
	Part Number	Part Number	Part Number
Compressor	0665-101	0665-107	0665-33
Compressor Capacitor	N/A	N/A	0452-12
Condenser Blower Motor	0261-08	0261-54	0261-54
Condenser Blower Motor Capacitor	0452-03	0452-06	0452-06
Condenser Blower Assembly	609033-00-124	609033-00-125	609033-00-125
Evaporator Blower Motor	0261-97	950-005-89	950-005-89
Evaporator Blower Motor Capacitor	0452-03	0452-03	0452-03
Evaporator Blower Assembly	609033-00-93	609033-00-92	609033-00-92
Filter	12251F	12251F	12251F

NOTE: Part Numbers shown are for 60Hz/1Ø. For 50Hz consult Kooltronic.

## Standard Features

*Built-in Condensate Evaporator*

**CFC-Free or Low-ODP Refrigerant**

*EMI/RFI Suppressor*

*Low Temperature Control Thermostat*

*M/TAB Mounting System*

**NEMA 12 Rating Maintained (UL50)**

*Reversible Condenser Outlet Blower*

**UL/CUL Listed**

# Wiring Schematic

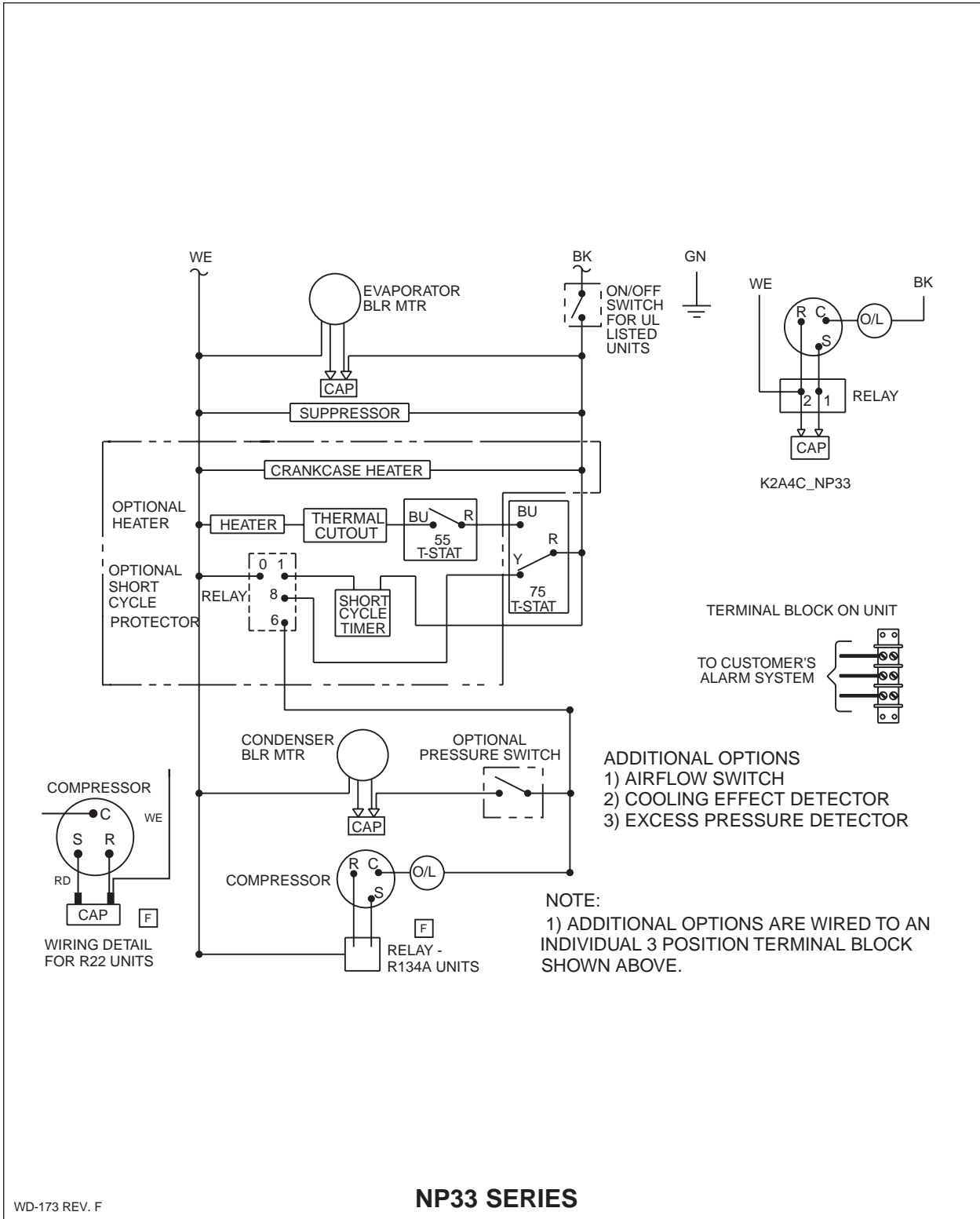

WD-173 REV. F

## NP33 SERIES

## **VIII. Maintenance**

Kooltronic Water-Cooled Air Conditioners require no maintenance. Air-Cooled Air Conditioners are designed to require only the routine cleaning of air filters to assure unimpeded air flow through the condenser heat exchanger. It is not possible to recommend specific filter cleaning intervals since the level and the nature of airborne particulate matter differs widely with each installation. It is generally sufficient to remove and wash the reusable aluminum mesh air filters when the outer surfaces of these filters appear covered with a thin layer of dust or lint. Filter recoating adhesive is recommended. Appropriate disposable filters are available from Kooltronic.

If filter service is neglected or delayed, the air conditioner will not perform at its design capacity. The first indication of excessively clogged air filters is usually a gradual increase of temperature within the equipment cabinet. If operation is continued under these conditions, the compressor will be shut off by the thermal overload device. The compressor will restart when its external temperature drops below the protector threshold setting and the compressor will continue to cycle on and off. Continued operation under these conditions will cause damage, shorten compressor life and void the warranty.

### **A. Filter Removal and Service**

Kooltronic Air Conditioners feature an easily removable inlet filter to facilitate necessary cleaning.

### **CAUTION**

**Do not operate the Air Conditioner for extended periods of time with the filter removed. The condenser coil may become clogged with dust or lint from the air entering the face. A clogged condenser coil is not readily detected and will give the same reaction as a clogged filter. A clean filter is the best protection.**

- 1) Lift the filter, using the attached tab, to clear the lower filter retainer. Pull filter toward you and downward until the top of the filter clears the upper filter retainer.
- 2) After removal, the filters should be flushed under warm running water with the clean side up, driving contaminants out the dirty side of the filter. If the accumulated dirt is oily, washing in a detergent bath is recommended, followed by a warm water rinse as above.
- 3) The filters may be sprayed with **Kooltronic A-16 Filter Recoating Adhesive** to trap fine airborne contaminants, or they may simply be dried and reinstalled as strainer type filters. **Recoating is recommended for best results.**
- 4) Reinstall the filter: (a) keeping the tab at the bottom, slide filter into the upper retainer, (b) press filter against the unit and (c) slide down into lower retainer.

## B. Blowers

The design life of the blowers employed in all Kooltronic Air Conditioners is substantially in excess of 20,000 hours. All Kooltronic condenser and evaporator blowers are equipped with UL/CSA permanently-lubricated precision ball-bearing motors, with automatic-reset thermal overload protectors.

### **CAUTION**

**Before opening the Air Conditioner, disconnect all power.**

If field replacement of a blower motor is necessary, most blower assemblies, including mounting plate, are readily removable. Each of the blower mounting plates is held to the air conditioner cabinet structure by screws and nuts. For installation of the replacement blower, electrical connections may be broken at the terminal block, or power leads may be cut and appropriately spliced together.

## C. Compressor

All Kooltronic compressors are approved by UL and CSA, and require no maintenance. They are hermetically sealed and charged at the factory, and equipped with automatic-reset thermal overload protectors.

If the compressor or the hot gas bypass valve fails, it is strongly recommended that the Air Conditioner be returned to Kooltronic for service.

## D. Refrigerant Loss

Kooltronic Air Conditioners are subjected to a series of tests to detect refrigerant leaks, during and after manufacture. It is possible that shipping or other damage, or microscopic leaks over a long period, may result in the need for replenishment of refrigerant charge. **When it has been verified by a qualified professional that a refrigerant shortage does exist, the leak must be repaired. Then the unit may be evacuated and recharged in the field by qualified service people only.**

### **CAUTION**

**Refer to the data on the unit name plate which specifies the type of refrigerant and the amount of charge in ounces.**

## E. Relocation

If your Kooltronic Air Conditioner has to be moved to another location by truck, the following precautions should be taken:

- De-mount Air Conditioner from equipment, controller or enclosure.
- Conform to the applicable provisions of PROCEDURE FOR PROPER PACKING AND SHIPMENT OF KOOLTRONIC AIR CONDITIONERS in this manual under *Section III. "PRODUCT HANDLING"*.

## IX. Trouble-Shooting

Each Kooltronic Air Conditioner is engineered for performance and built for reliability. They are designed to require no routine maintenance other than the cleaning of ambient air filters. If your air conditioner should require service, we have compiled a trouble-shooting chart to assist your service personnel. If additional assistance is required contact Kooltronic at 609 • 466-3400.

<b>Problem</b>	<b>Cause</b>	<b>Solution</b>
Unit not Cooling	No Power	Check Power Source and Electrical Connections
	Loss of Refrigerant	Locate and repair leak
	Evaporator or Condenser Blower not operating	Replace Motor, Capacitor or entire Assembly
	Filter clogged	Clean or replace Filter
	Clogged Evaporator or Condenser Coil	Clean Coil
	Low Temperature Control (Thermostat) improperly set	Lower setting until unit starts
	Low Temperature Control (Thermostat) defective	Replace Thermostat or Relay when applicable
	Failed Compressor	Replace Compressor
Ice on Evaporator Coil	Insufficient Heat Load or Unit Oversized for Application	Contact Kooltronic
	Failed Evaporator Blower	Replace Evaporator Blower Motor or Assembly
	Clogged Evaporator Coil	Clean Coil
Condensate draining continuously	Enclosure not properly sealed	Check and seal all openings
	Excessive opening of Enclosure	Eliminate the frequency of door opening
Excessive vibration	Defective Motor in Blower	Replace Motor
	Defective Wheel in Blower	Replace Wheel
	Compressor Loose	Tighten Mounting Bolts
Compressor Inoperative	Low line Voltage	Check Nameplate Voltage against supply
	Loss of Compressor Oil	Replace Compressor
	Loss of Refrigerant	Locate and repair leak
	Failed Compressor Capacitor	Replace Capacitor
	Thermal Overload	Contact Kooltronic
	Power interruptions	Allow Compressor time to reset
Refrigerant or Oil leaks	Crack or pin hole in tubing or brazed joint	Replace tubing or rebrase joint

## X. Accessories

Accessories and Options	Air Cooled							Water Cooled	
	Panel Mounted						Rack Mounted (H & V)	Horizontal Top Mounted (HT)	Panel Mounted (WP)
	Mini		P24 P28 P36	P47 P52 P59*	NP33 NP36 NP47 NP59				
	MM SM	HS NM NP17							
Adapter Plate for Rack Mounting	•	N/A	N/A	N/A	N/A	N/A	N/A	N/A	
Air Deflectors	•	•	•	•	•	•	•	N/A	
Airflow Switch	• <sup>E</sup>	N/A	•	•	•	•	•	•	
Compressor Heater	•	•	•	•	•	•	•	•	
Condenser Access Panel	N/A	N/A	N/A	•	N/A	N/A	N/A	•	
Condensate Evaporator Kit	• <sup>F</sup>	Std.	•	•	Std.	• <sup>B</sup>	Std.	•	
Cooling Effect Detector	• <sup>A</sup>	•	•	•	•	•	•	•	
Deep Drain Pan Kit	X	N/A	• <sup>C</sup>	•	N/A	Std.	Std.	•	
Excess Pressure Detector	• <sup>A</sup>	•	• <sup>D</sup>	•	•	•	•	•	
Filter Recoating Adhesive	•	•	•	•	•	•	•	N/A	
Filters for replacement	•	•	•	•	•	•	•	N/A	
Internal Corrosion Resistance	•	•	•	•	•	•	•	•	
Lifting Eyes	N/A	N/A	•	•	•	•	•	•	
Low Airflow Detector	• <sup>E</sup>	N/A	•	•	•	•	•	•	
Low Ambient Kit	X	X	X	•	X <sup>K</sup>	X	X	N/A	
Low Temperature Control	• <sup>A</sup>	Std.	•	•	Std.	•	•	•	
M/TAB**	N/A	Std. <sup>H</sup>	N/A	N/A	Std.	N/A	N/A	N/A	
Mounting Hinge	•	N/A <sup>J</sup>	•	•	N/A	N/A	N/A	•	
Rear Condenser Air Inlet Panel	Std.	Std. <sup>H</sup>	Std.	•	Std.	N/A	N/A	N/A	
Refrigerant Charging Kit	•	•	•	•	•	•	•	•	
Short Cycle Protector	• <sup>A</sup>	•	•	•	•	•	•	•	
Special External Paint Finishes	•	•	•	•	•	•	•	•	
Special Line Cord or Connectors	•	•	•	•	•	•	•	•	
Surge Suppressor	•	Std.	•	•	Std.	•	•	•	
Switchable Power (50/60Hz)	•	•	•	•	•	•	•	•	
Unit Heaters	X	• <sup>G</sup>	•	•	•	•	•	•	
Weather Protection Kit	•	•	•	•	•	•	•	N/A	

- Available
- \* 18,000-22,000 BTU/H P59 accessories and options same as NP59
- \*\* Mounting Template & Assembly Bracket
- X Not available due to design configuration

- A Micro-Mini has internal space available for only one of these options. All others are mounted externally.
- B Standard on H models
- C Standard on P24
- D Not available on P24 series

- E N/A on Micro-Mini
- F Standard on Super-Mini
- G N/A on Narrow-Mini
- H N/A on HS
- J Available on NP17
- K Available on NP59

**CONDENSATE EVAPORATOR KIT:** This device attaches to bottom of Air Conditioner. Condensate is collected, vaporized and discharged to ambient.

**COOLING EFFECT DETECTOR:** A thermostat is mounted inside the cabinet and attached to a sensor in the warm air return. When the air temperature increases to a set point, a signal is sent to a terminal block. Requires user-installed wiring to a warning device.

**EXCESS PRESSURE DETECTOR:** Monitors head or condensing pressure within the Air Conditioner. When the pressure reaches an unsafe level a switch sends a signal to the terminal block. Requires user-installed wiring to a warning device.

**LOW TEMPERATURE CONTROL:** Recommended in situations of extremely low ambient temperatures and/or low internal loads. At a pre-set return air temperature, the Thermostat shuts down the unit, except for the evaporator blower, for continuous cabinet air circulation.

**SHORT CYCLE PROTECTOR:** Protects the compressor from damage due to harmful short cycling after a power interruption. Protector keeps compressor off for 5 to 6 minutes before resumption of operation.

**WEATHER PROTECTION KIT:** For outdoor installations subject to invasion by rain, snow or windblown dirt, special deflectors shield the condenser air inlet and outlet ports.